

Swinsol AG

Bahnhofstrasse 6-8
CH-9434 Au
Switzerland

T +41 71 510 92 51
F +41 71 510 92 59
www.swinsol.com
info@swinsol.com

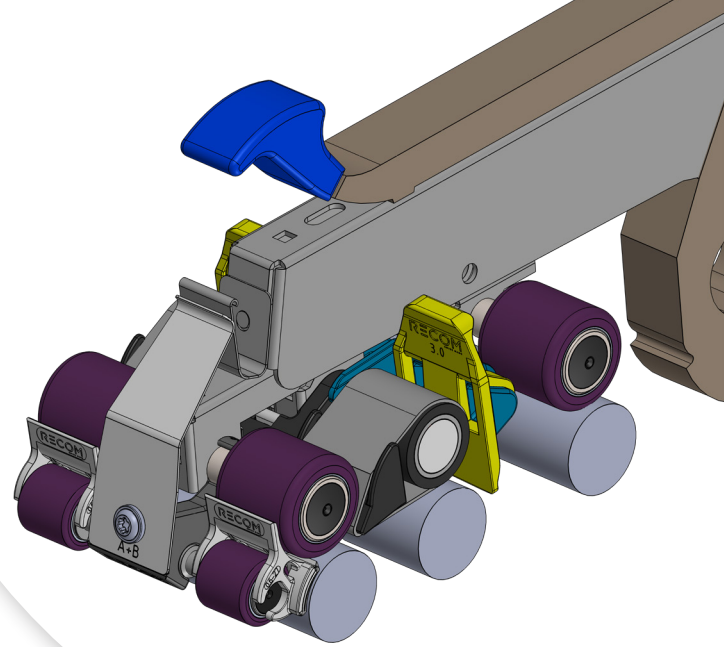

Comparison

Maintenance Schedule

Mechanical compacting solution for all types of ring spinning frames



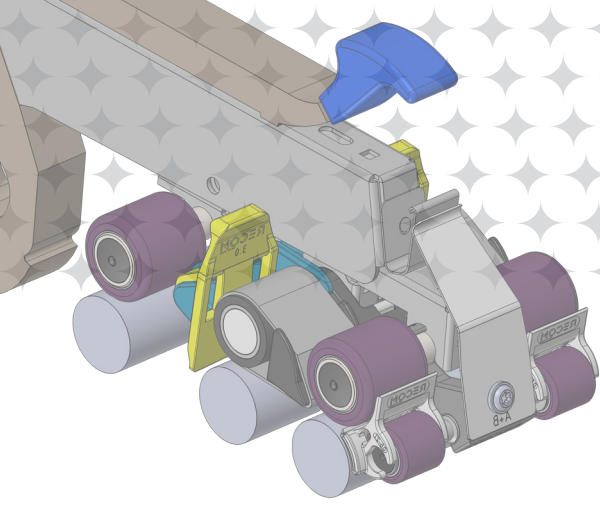

Recompact 2.0 & 3.0 Maintenance Schedule

Maintenance Parts	RECOMPACT 2.0	RECOMPACT 3.0
Front Roller Reversing	• 15 Days	• not required
Front Roller Cots Grinding	• 30 Days	• 45 Days
Delivery Roller Reversing	• 5 - 6 Months	• not required
Delivery Roller Cots Grinding	• 10 - 12 Months	• 15 - 18 Months
Apron Reversing	• 6 Months	• not needed
Apron Change	• 12 Months	• 18 Months
Wing Changing Frequency	• no wings • uses reversing	• 15 days
Maintenance Task	Reversing the front roller + piecing	Changing the wings while running
Maintenance Time per 1 Spindle 1000 spindles	≈ 20 seconds ≈ 5 hours	≈ 5 seconds ≈ 1 hour 23 minutes

RECOMPACT 3.0 BENEFITS

- Up to 50% longer lifetime of the cots and aprons compared to Recompact 2.0
- Maintenance time reduced by at least 50% in comparison with Recompact 2.0
- No production losses / no downtime / change roving path while running / no reversing / longer grinding cycles